



Company honor

- 1988 Synthesis of Funik's first high-grade cubic boron nitride abrasive
- 1991 Amber cubic boron nitride has been successfully developed
- 1997 High strength black cubic boron nitride has been successfully developed
- 1998 Won the title of "High-tech Enterprise" of Henan Science and Technology Commission
- 2002 National standard formulation unit of Super Abrasive, Cubic Boron Nitride
- 2003 Introduced high wear-resistant and impact-resistant polycrystalline cubic boron nitride inserts
- 2003 Undertook the "National Torch Plan" project of the Ministry of Science and Technology of the People's Republic of China
- 2005 Funik brand won the title of "Famous Brand Products of Henan Province"
- 2006 Won the "50 High-Tech and High-growth Enterprises" named by Henan Provincial Government
- 2006 The first one in the industry was certified by the "three-standard" management system of ISO9001, ISO14001, OHSAS18001
- 2007 Won the title of "Top Ten Enterprises with Comprehensive Economic Benefits in 2006" by China Machine Tool Industry Association
- 2008 Super wear-resistant high-speed finishing polycrystalline cubic boron nitride inserts were successfully put on the market
- 2009 Undertook and implemented the high-tech industrialization project of high-grade cubic boron nitride and high-speed cutting superhard cutting tools of the National Development and Reform Commission
- 2009 Won the title of "Henan Innovative Enterprise" in Henan Province
- 2010 Super brazed cubic boron nitride cutting tools was successfully put on the market
- 2011 Establishment of academician workstation of cubic boron nitride and its products
- 2012 Ultra-precision cubic boron nitride polycrystalline cutting tools was successfully put on the market
- 2014 Won the title of "Innovative Enterprise" of China Materials Research Society
- 2014 The company's shares are listed on the New Three Board, and the securities are referred to as "Funik". The stock code is 831378
- 2015 Won the national standard-setting unit of Polycrystalline Cubic Boron Nitride for Metal Processing
- 2015 Won the title of "Demonstration Enterprise of Technological Innovation in Henan Province in 2015"
- 2015 Won the title of "Top Ten Innovative Enterprises of Henan Economy (2015)"
- 2016 Won the title of "Intellectual Property Advantage Enterprise in Henan Province"
- 2016 Won the title of "Top Ten Product Quality" of cubic boron nitride awarded by China Machine Tool Industry Association
- 2016 Won the title of "Best Service Brand" of the third China Metal Cutting Tool
- 2017 Won the "Excellence Award of China Patent Award"
- 2017 Won the "First Prize for Scientific and Technological Progress in Henan Province"
- 2017 Won the "Top Ten Brands Made in Henan Province in 2017"
- 2018 Obtained the first batch of demonstration items of robot "Ten Hundred Thousand" demonstration application multiplication project in Henan Province in 2018
- 2018 Won the "First Prize for Scientific and Technological Progress in Henan Province"
- 2018 Funik innovative PCD cutting tool was sold more than 200,000 pieces in 3C electronics industry
- 2018 The $\Phi 63\text{mm}$ PCD blank was successfully put on the market
- 2018 Won the title of "Henan Intelligent Factory"
- 2019 Won the title of the first batch of special new "Little Giant" enterprises of the Ministry of Industry and Information Technology of the People's Republic of China
- 2019 Won the "Henan Science and Technology Progress Award"
- 2019 Won the "National Intellectual Property Advantage Enterprise"
- 2020 Passed the evaluation of the "Management System for Integration of Informatization and Industrialization"
- 2020 Won the recognition of Henan Research Center of Cubic Boron Nitride Micro-nano Materials and Applied Engineering Technology
- 2021 Funik holds 370 national patents
- 2021 Premium quality Lab-grown diamond was successfully put on the market
- 2021 High performance $\Phi 75\text{mm}$ PCD Blank was successfully put on the market

Funik Ultrahard Material Co., Ltd.

Address: No. 9, Wutong West Street, High-tech Industrial Development Zone, Zhengzhou City, Henan Province, China 450001

Tel: +86-371-67987271

Fax: +86-371-67997700

Email: export@funik.com

Website: en.funik.com



PCD cutting tool

Substantially improve cutting efficiency and tool life

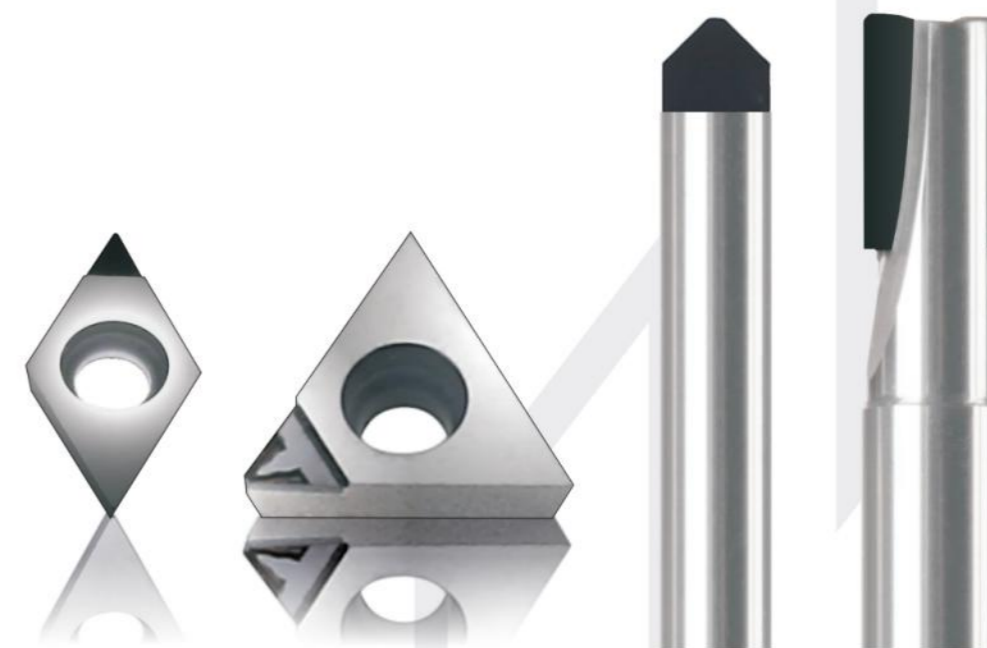

Subverting the tradition Enlightening the future

ISO9001/ISO14001/ISO45001 Certified

PCD insert

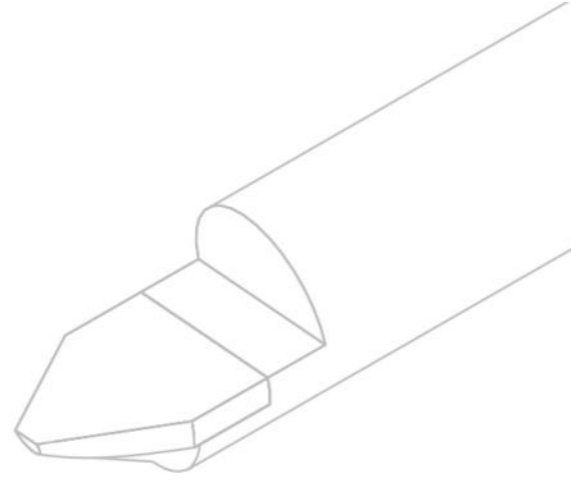

In 2008, Funik set up the world's top research center of super hard material - composite materials - cutting tool application integration, which further strengthened our leading position in the field of super hard materials research. Additionally, the huge R&D investment and the close joint with customers enable us to find new methods to transform the premium feature of the super hard materials into the products with innovative performance. There are obvious advantages in both performance and price compared with our competitors.

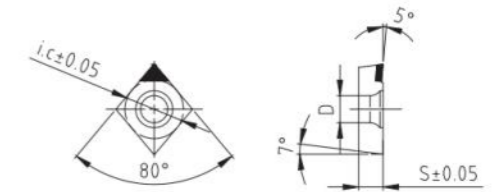
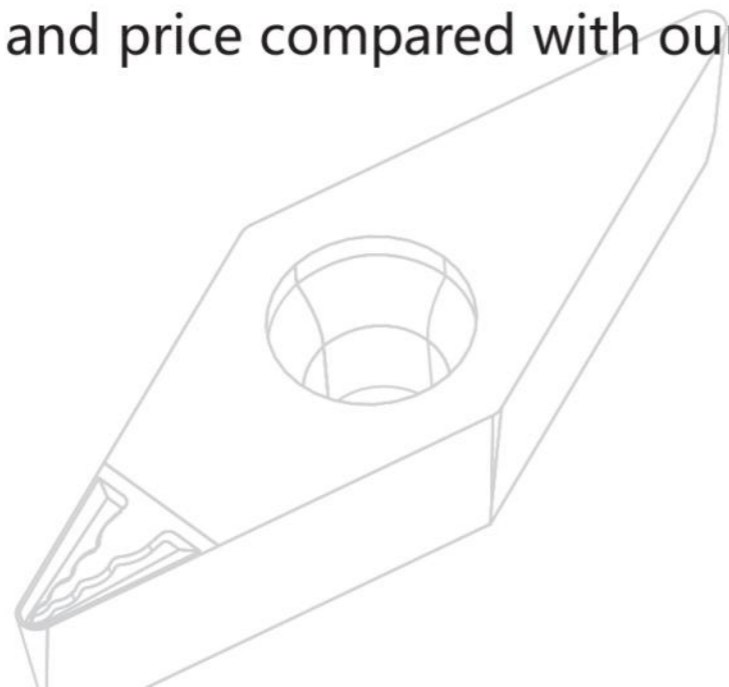

Grade	Model No.	ϕ i.c	S	R	D
5685	CCGW09T302	9.525	3.97	0.2	4.4
5685	CCGW09T304	9.525	3.97	0.4	4.4
5685	CCGW120404	12.7	4.76	0.4	5.5
5685	CCGW120408	12.7	4.76	0.8	5.5

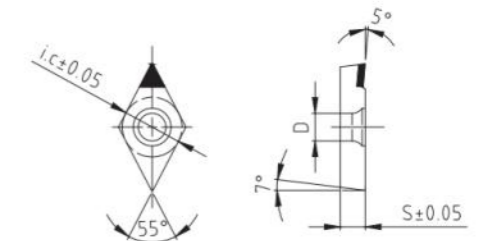

Grade	Model No.	ϕ i.c	S	R	D
5685	DCGW11T302	9.525	3.97	0.2	4.4
5685	DCGW11T304	9.525	3.97	0.4	4.4
5685	DCGW11T308	9.525	3.97	0.8	4.4

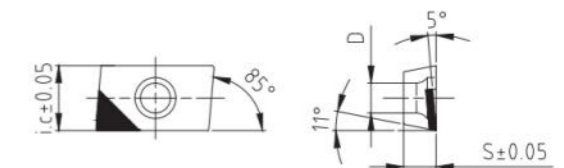
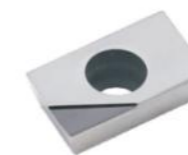

Grade	Model No.	ϕ i.c	S	R	D
5685	APKT160402	9.525	4.76	0.2	4.4
5685	APKT160404	9.525	4.76	0.4	4.4
5685	APKT160408	9.525	4.76	0.8	4.4

PCD insert

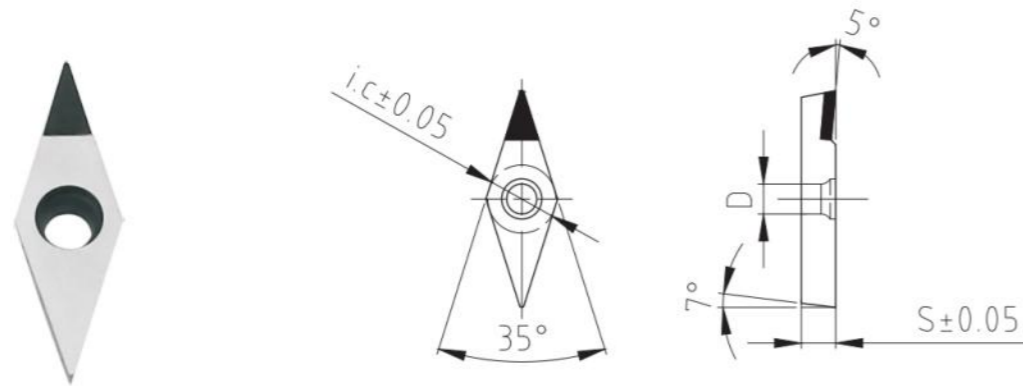

Grade	Model No.	φi.c	S	R	D
5685	VCGW11T302	6.35	3.97	0.2	2.8
5685	VCGW11T304	6.35	3.97	0.4	2.8
5685	VCGW160404	9.525	4.76	0.4	4.4
5685	VCGW160408	9.525	4.76	0.8	4.4

PCD insert - chip breaker

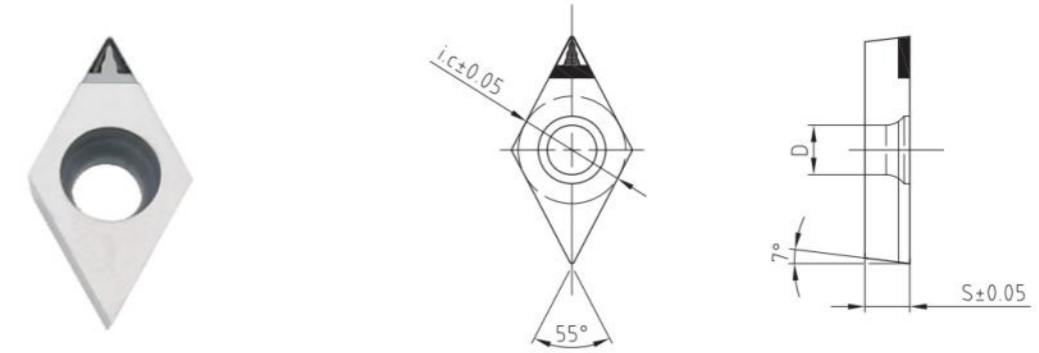

Grade	Model No.	φi.c	S	R	D
5685	DCGW11T302	9.525	3.97	0.2	4.4
5685	DCGW11T304	9.525	3.97	0.4	4.4
5685	DCGW11T308	9.525	3.97	0.8	4.4

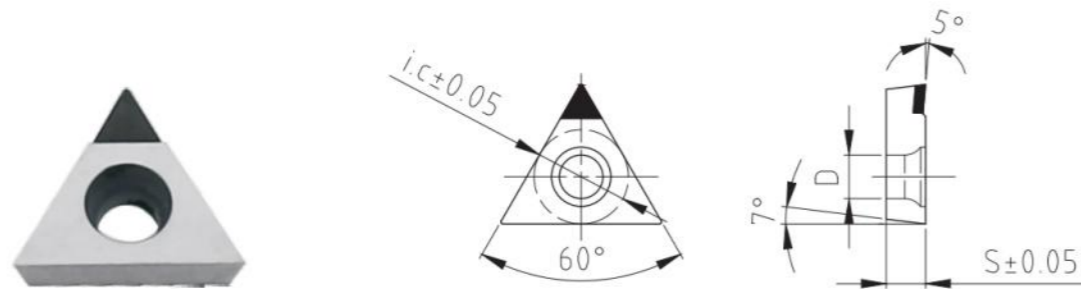

Grade	Model No.	φi.c	S	R	D
5685	TCGW110302	6.35	3.18	0.2	2.8
5685	TCGW110304	6.35	3.18	0.4	2.8
5685	TCGW160404	9.525	4.76	0.4	4.4
5685	TCGW160408	9.525	4.76	0.8	4.4

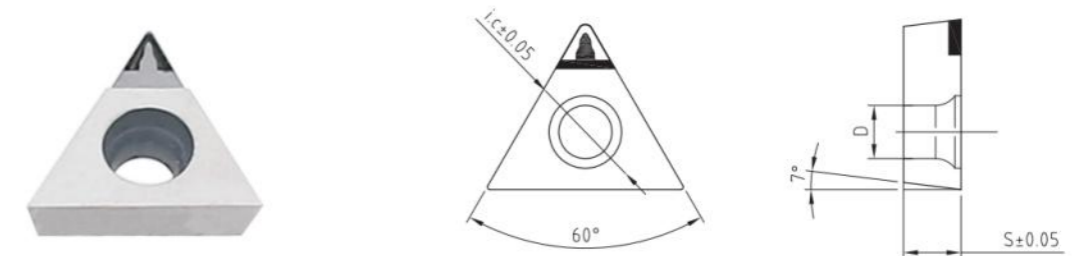

Grade	Model No.	φi.c	S	R	D
5685	TCGW110302	6.35	3.18	0.2	2.8
5685	TCGW110304	6.35	3.18	0.4	2.8
5685	TCGW160404	9.525	4.76	0.4	4.4
5685	TCGW160408	9.525	4.76	0.8	4.4

PCD cutting tool for stone carving

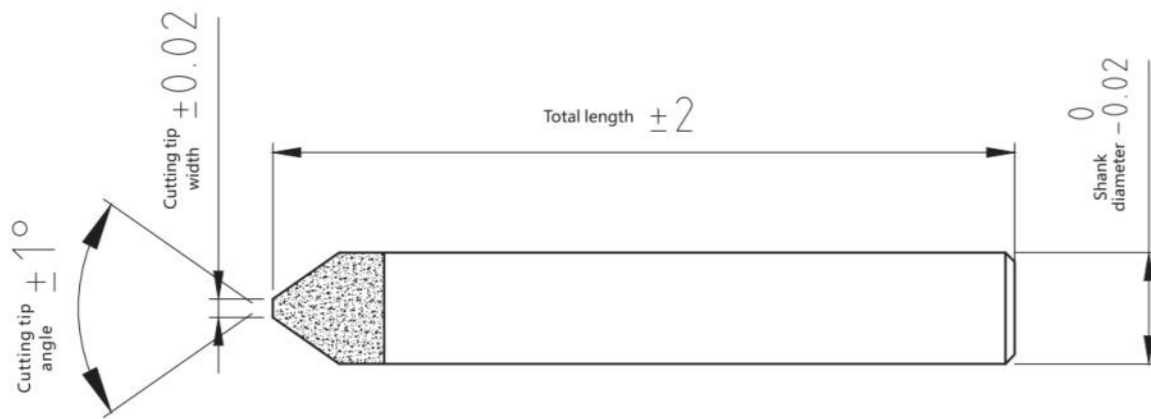

PCD milling cutter

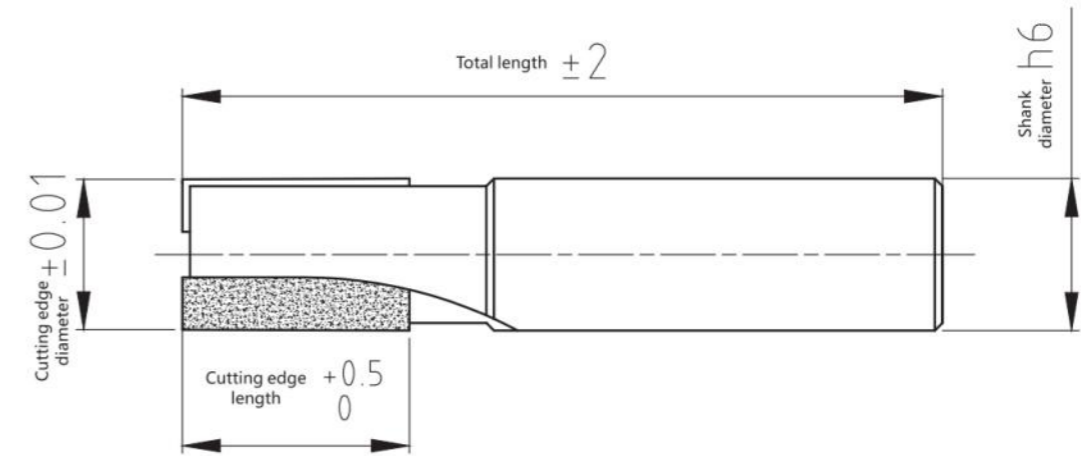

Grade	Cutting tip width (mm)	Cutting tip angle	Shank diameter (mm)	Total length (mm)
5632	0.2	45°	6	40
5632	0.4	45°	6	40
5632	0.2	60°	6	40
5632	0.4	60°	6	40
5632	0.2	70°	6	40
5632	0.4	70°	6	40
5632	1	70°	6	40
5632	2	70°	6	40
5632	0.2	90°	6	40
5632	0.4	90°	6	40
5632	1	90°	6	40
5632	2	90°	6	40



Grade	Cutter diameter (mm)	Cutting edge length (mm)	Number of cutting edge	Shank diameter (mm)	Total length (mm)
5610	2	3	1	4	40
5610	3	4	1	6	40
5610	4	6	1	6	40
5610	10	12	1	10	50
5610	12	12	1	10	50
5610	4	12	2	10	50
5610	6	12	2	10	50
5610	8	12	2	10	50
5610	10	12	2	10	50
5610	12	12	2	10	50